



Permanent Magnet Synchronous Technology

Empowering Energy Efficiency

Ensuring Quality Excellence

Enabling a Low-Carbon Future

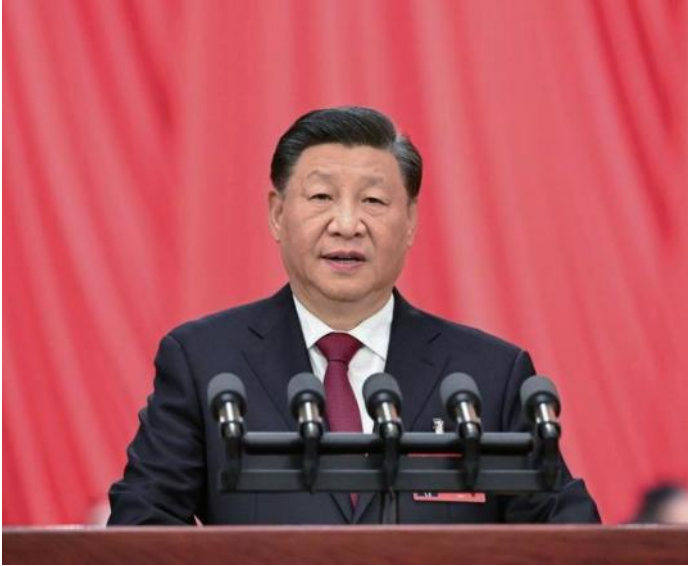

Xi Jinping

President of the People's Republic of China

"We must firmly embrace and act on the philosophy that lucid waters and lush mountains are invaluable assets, and pursue development from the perspective of harmonious coexistence between humanity and nature.

We need to accelerate the green transition of development patterns. We will develop green and low-carbon industries, improve the market-based allocation system for resources and environmental factors, speed up the R&D, popularization and application of advanced energy-saving and carbon-reduction technologies, and promote the formation of green and low-carbon production modes.

We will also actively and prudently advance carbon peaking and carbon neutrality. We will improve the regulation of total energy consumption and energy consumption intensity, and gradually shift to a 'dual control' system covering both total carbon emissions and carbon emission intensity. We will refine the statistical accounting system for carbon emissions and improve the market trading system for carbon emission rights. We will enhance the carbon sink capacity of ecosystems."

Excerpt from the Report to the 20th National Congress of the Communist Party of China



Profile

World Focus Energy Technology (Beijing) Co., Ltd. (WDFCS) is a national-level innovative high-tech enterprise dedicated to delivering professional motor energy efficiency upgrade solutions and services across all industrial sectors and comprehensive application scenarios. The company strives to become a global leader in the high-efficiency rare-earth permanent magnet synchronous motor industry.

Backed by a core R&D team with more than 30 years of experience in the R&D and engineering of rare-earth permanent magnet synchronous motors, the company applies world-leading technologies and advanced manufacturing processes across its entire production system. This guarantees manufacturing precision and operational stability throughout the production chain, while significantly enhancing the high-efficiency and energy-saving performance of its permanent magnet synchronous motors. By doing so, the company helps customers achieve green and low-carbon operations, and contributes to the national goals of carbon peaking and carbon neutrality.

Contents

01
Policy
Guidelines

02
Company
Overview

03
Corporate
Qualifications

04
Product
Introduction

05
Project
Showcase



01 On March 12, 2026, the Eco-Environmental Code of the People's Republic of China guides the whole society to conserve and intensively use energy, improve energy efficiency, strictly guard the ecological and environmental bottom line, and boost the high-quality and sustainable development of the economy and society.

02 On May 23, 2024, the State Council issued the Action Plan for Energy Conservation and Carbon Reduction 2024–2025 (Guo Fa [2024] No. 12), which vigorously promotes the application of rare-earth permanent magnet motors and high-efficiency energy-saving motor technologies.

03 From 2024 to 2026, China will speed up the phase-out of outdated, low-efficiency electromechanical equipment including motors and transformers under the Catalogue for the Guidance of Industrial Structure Adjustment (2024 Edition), mandatory energy efficiency standards and equipment renewal policies, while promoting high-efficiency and energy-saving products.

04 In line with the 15th Five-Year Plan supporting policies including the Implementation Plan for High-Quality Development of Energy-Saving Equipment (2026–2028), China keeps upgrading motor system efficiency, promoting high-efficiency motors and carrying out energy-saving retrofits.

05 MIIT Notice on Industrial Energy Conservation Supervision Work for 2025 (Gongxing Jiehan [2025] No. 223) mandates mandatory energy efficiency inspections on key equipment including electric motors, transformers, fans, pumps and air compressors. Enterprises must lawfully phase out inefficient products failing to comply with mandatory national energy efficiency standards.

06 On May 24, 2025, the General Office of the CPC Central Committee and the General Office of the State Council issued the Opinions on Promoting Green and Low-Carbon Transition and Strengthening the Development of the National Carbon Market, which takes improving energy efficiency and optimizing resource allocation as key work objectives.

Policy Orientation – Energy Efficiency Standard System

- High-efficiency, energy-saving and green development has become the future trend of the motor industry. Promoting high-efficiency energy-saving motor technologies and products, advancing energy-saving retrofits of motor systems, improving the motor energy efficiency standard system, strengthening supervision of energy efficiency standards, and conducting industrial energy efficiency testing will be important measures to improve motor energy efficiency.
- On September 29, 2024, the Standardization Administration of the People's Republic of China (SAC) issued the mandatory national standard GB 30253-2024, which will take effect on October 1, 2025. It stipulates that the minimum energy efficiency value for permanent magnet synchronous motors shall be IE4, and products below this level shall not be produced or sold.
- China's motor industry has fully entered the era of IE4 super-premium efficiency. Our permanent magnet synchronous motors (PMSM) not only meet the stringent IE5 ultra-premium efficiency standard (the highest international energy efficiency grade for motors), but also achieve the highest Grade 1 rating under China's latest national energy efficiency standard (GB 30253-2024), delivering industry-leading energy savings for industrial customers.

Energy Efficiency Standards

IEC 60034-30-2:2016 International Standard	GB 30253-2024 China's Latest National Standard	GB 18613-2020 China's Current National Standard
IE5	Grade 1 Energy Efficiency	
IE4	Grade 2 Energy Efficiency	Grade 1 Energy Efficiency
IE3	Grade 3 Energy Efficiency	Grade 2 Energy Efficiency
IE2		Grade 3 Energy Efficiency

检测报告			
编号: 3N230746		共 5 页 第 1 页	
样品名称	高效永磁三相同步电动机	规格型号	TYWF-225M-8/66.6
		商标	WDFCS
抽(送)样单序号	/	样品等级	合格品
抽(送)样地点	/	样品数量	1台
抽(送)样日期	/	样品基数	/
到样日期	2023-07-21	原编号或生产日期	2023年5月
检测完成日期	2023-07-26		
检测和判定依据	GB 30253-2013、GB/T 22670-2008		
检测项目	效率		
检测结论	对沃德福斯能源科技(北京)有限公司生产的规格型号为 TYWF-225M-8/66.6 永磁同步电动机按照 GB 30253 的相关要求进行检测, 所检项目均合格, 其能效等级为 1 级。 (以下空白)		
	 2023年08月02日		

检测报告			
编号: 3N230745		共 5 页 第 1 页	
样品名称	高效永磁三相同步电动机	规格型号	TYWF-280S-6/75
		商标	WDFCS
抽(送)样单序号	/	样品等级	合格品
抽(送)样地点	/	样品数量	1台
抽(送)样日期	/	样品基数	/
到样日期	2023-07-21	原编号或生产日期	2023年5月
检测完成日期	2023-07-25		
检测和判定依据	GB 30253-2013、GB/T 22670-2008		
检测项目	效率		
检测结论	对沃德福斯能源科技(北京)有限公司生产的规格型号为 TYWF-280S-6/75 永磁同步电动机按照 GB 30253 的相关要求进行检测, 所检项目均合格, 其能效等级为 1 级。 (以下空白)		
	 2023年08月02日		

检测报告			
编号: 3W230213		共 5 页 第 1 页	
样品名称	高效永磁三相同步电动机	规格型号	TYWF-355M1-8/50
		商标	WDFCS
抽(送)样单序号	/	样品等级	合格品
抽(送)样地点	/	样品数量	1台
抽(送)样日期	/	样品基数	/
到样日期	2023-07-21	原编号或生产日期	2023年5月
检测完成日期	2023-07-31		
检测和判定依据	IEC 60034-30-2:2016、GB/T 22670-2018		
检测项目	效率		
检测结论	对沃德福斯能源科技(北京)有限公司生产的规格型号为 TYWF-355M1-8/50 永磁同步电动机按照 IEC 60034-30-2 的相关要求进行检测, 所检项目均合格, 其能效等级为 IE5。 (以下空白)		
	 2023年08月02日		

POLICY GUIDELINES

The energy efficiency of WDFCS rare-earth permanent magnet synchronous motors is compared with GB 30253-2024 Minimum Allowable Values of Energy Efficiency and Energy Efficiency Grades for Permanent Magnet Synchronous Motors and GB 18613-2020 Minimum Allowable Values of Energy Efficiency and Energy Efficiency Grades for Electric Motors. The efficiency at all power ranges and speeds exceeds the requirements of Grade 1 energy efficiency in the latest standards.

Power (kW)	3000 rpm	1500 rpm	1000 rpm
	Efficiency (%)	Efficiency (%)	Efficiency (%)
11	95	93.6	94.5
15	95.3	94	94.9
18.5	95.6	94.3	95.3
22	95.9	94.7	95.6
30	96.1	95	95.8
37	96.3	95.3	96
45	96.4	95.6	96.2
55	96.5	95.8	96.3
75	96.6	96	96.4
90	96.7	96.2	96.5

Power (kW)	3000 rpm	1500 rpm	1000 rpm	750 rpm
	Efficiency (%)	Efficiency (%)	Efficiency (%)	Efficiency (%)
11	94	94.6	93.7	92.2
15	94.5	95.1	94.3	92.9
18.5	94.9	95.3	94.6	93.3
22	95.1	95.5	94.9	93.6
30	95.5	95.9	95.3	94.1
37	95.8	96.1	95.6	94.4
45	96	96.3	95.8	94.7
55	96.2	96.5	96	94.9
75	96.5	96.7	96.3	95.3
90	96.6	96.9	96.5	95.5
110	96.8	97	96.6	95.7
132	96.9	97.1	96.8	95.9
160	97	97.2	96.9	96.1
200	97.2	97.4	97	96.3
250	97.2	97.4	97	96.3
315 - 1000	97.2	97.4	97	96.3

Power (kW)	3000 rpm	1500 rpm	1000 rpm	750 rpm
	Efficiency (%)	Efficiency (%)	Efficiency (%)	Efficiency (%)
11	94.2	94.7	93.9	92.5
15	94.7	95.2	94.5	93.1
18.5	95.1	95.4	95	93.5
22	95.3	95.7	95.1	93.8
30	95.8	96.1	95.5	94.4
37	96	96.3	95.8	94.6
45	96.2	96.5	96	94.8
55	96.4	96.6	96.2	95.1
75	96.7	96.8	96.5	95.5
90	96.8	97	96.7	95.7
110	97	97.2	96.8	95.8
132	97.1	97.3	96.9	96.2
160	97.1	97.4	97	96.3
185	97.1	97.4	97.1	96.3
200	97.3	97.5	97.1	96.5
220	97.3	97.5	97.2	96.5
250	97.3	97.5	97.2	96.5
280	97.3	97.5	97.2	96.5
315	97.3	97.5	97.2	96.5
355	97.3	97.5	97.2	96.5
375	97.3	97.5	97.2	96.5



Implementation of the Motor Energy Efficiency Improvement Program

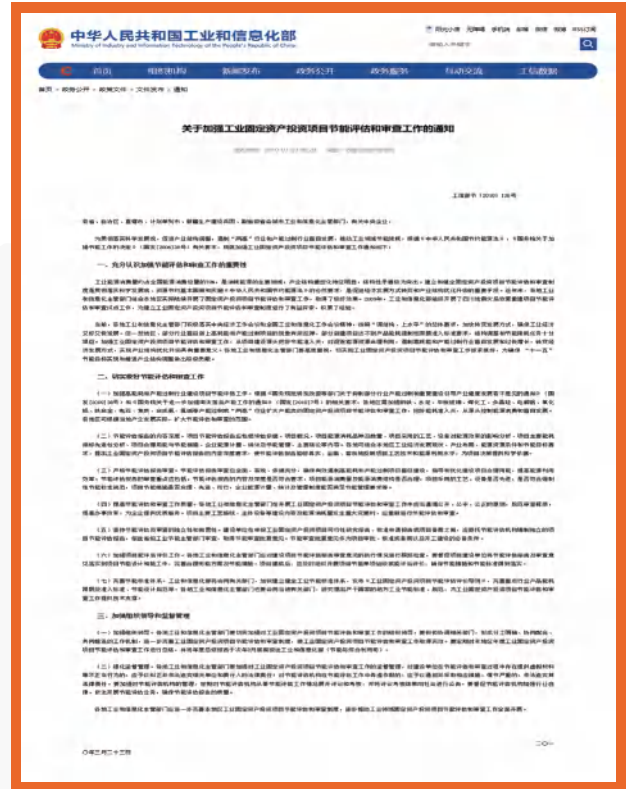

Mandatory Energy Efficiency Standards for Electric Motors

POLICY SUPPORT

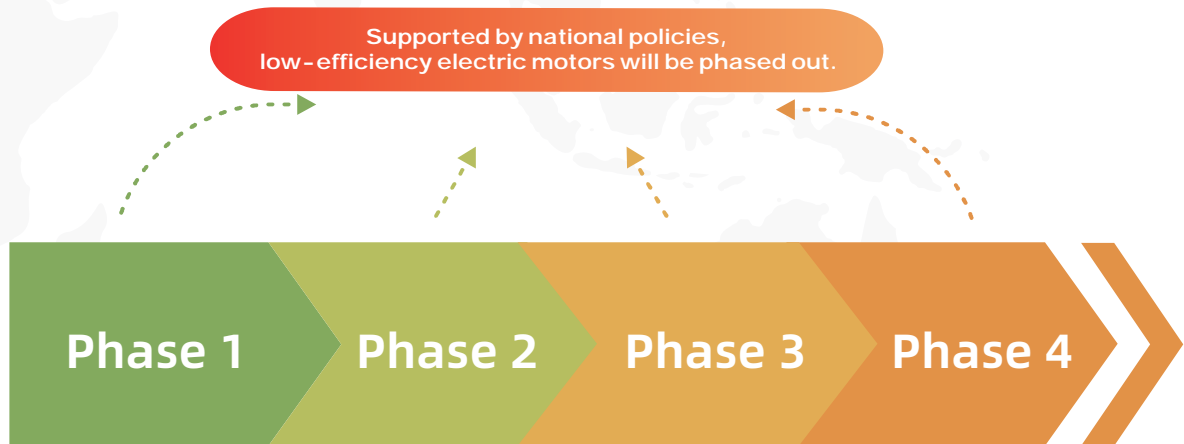

The Ministry of Industry and Information Technology has issued the Catalogue for the Elimination of High-Energy-Consuming Outdated Electromechanical Equipment (Products) four consecutive times.

The fourth catalogue covers a total of 127 items across three major categories: three-phase distribution transformers, electric motors, and arc welding machines.

Enterprises are required to discontinue the use of such equipment and replace them with high-efficiency energy-saving models within the specified time limit.

WORLD FOCUS ENERGY TECHNOLOGY (BEIJING) CO., LTD.



“

DRIVEN BY RESPONSIBILITY

COMMITTED TO EXCELLENCE

”

World Focus Energy Technology (Beijing) Co., Ltd. (WDFCS) is an innovative national high-tech enterprise delivering comprehensive motor energy-efficiency solutions across a wide range of industrial sectors. A global leader in high-efficiency rare-earth permanent magnet synchronous motors (PMSMs), the company provides reliable, durable, and ultra-efficient solutions that support sustainable industrial development.

With more than three decades of R&D excellence, WDFCS pioneered China's first industrial-grade, high-power rare-earth PMSM in 2009. Its portfolio today spans high-, medium-, and low-voltage motors, alongside low-speed, high-torque and high-speed solutions, complemented by remanufactured PMSMs engineered for seamless retrofit of legacy asynchronous systems.

The company's technologies are protected by numerous invention and utility model patents, with products repeatedly listed in the Ministry of Industry and Information Technology (MIIT) Energy-Saving Products Catalogue and recognized with the "Energy Efficiency Star" award since 2015. Certified to exceed Grade 1 requirements under GB 30253-2024, WDFCS motors deliver energy savings of 10%-40% compared with conventional induction motors. Widely deployed across metallurgy, cement, petrochemicals, mining, and water treatment, these solutions consistently achieve outstanding energy-efficiency performance.

Guided by a commitment to quality and efficiency, WDFCS focuses on advancing carbon peaking and carbon neutrality goals through continuous innovation and end-to-end service capabilities, delivering integrated, one-stop energy-efficiency solutions for industrial customers.

R & D Team

Wu Shu, Professor-level Senior Engineer | Chief Engineer

- Elite Academic & Industry Lineage: Bachelor's from University of Science and Technology Beijing; Master's from Shenyang University of Technology, mentored by Academician Tang Renyuan – renowned electrical engineering authority and Director of the National Engineering Research Center for Rare Earth Permanent Magnet Motors.
- Global R&D Leadership: Head of R&D at WDFCS, leading innovation in high-efficiency, sustainable motor systems.
- Pioneer in Rare Earth Permanent Magnet Motors: Academic and industrial trailblazer in synchronous motor development, shaping next-generation energy solutions.
- Industry Standard & Policy Influencer: Contributed to multiple national standards; recognized for outstanding standardization and technical innovation by leading industry associations.
- Award-Winning Innovation: Multiple "Energy Efficiency Star" awards from MIIT & NDRC; recipient of the 2024 Science & Technology Innovation Award from the China Building Materials Circulation Association; led projects awarded 2 First Prizes and 5 Second Prizes in provincial and ministerial science & technology progress.
- Patent Portfolio & Commercial Impact: Holder of numerous domestic and international patents; R&D outputs successfully translated into industrial-scale solutions.

Zhang Guilin, Professor-level Senior Engineer | Senior Technical Advisor

- Graduate of Harbin Institute of Technology, one of China's top-tier engineering institutions, specializing in Electrical Machine Engineering.
- Member of the National Standards Committee, actively contributing to the development and governance of industry standards.
- Dedicated to the research and innovation of high-efficiency permanent magnet motors and large-scale wind power generators.
- Focused on advancing next-generation motor systems for high-performance and sustainable energy applications.

Niu Ji | Operations Director

- Former Technical Director at multiple leading permanent magnet equipment companies.
- Deep involvement in the full lifecycle of high-efficiency and high-voltage permanent magnet motors, including R&D design, manufacturing processes, and system testing.
- Combines strong technical knowledge with hands-on industry experience in electrical drive systems and real-world applications.

Hu Hongyu, Structural Engineer | Core Technical Expert

- Dual-disciplinary academic and technical background in Chemical Engineering and Software Engineering
- Over 10 years dedicated to motor structural design, leading innovation in high-efficiency electrical machines.
- Pioneered core development of national first-class energy-efficient permanent magnet synchronous motors, overcoming traditional structural limitations, led multiple high-efficiency motor projects, boosting production efficiency by 40%.
- Developed "Multi-Dimensional Thermal Channel" cooling technology, reducing motor operating temperature by 15% and significantly enhancing operational stability.
- Participated in building national military standard processes, successfully translating permanent magnet motor lab research into defense applications.

Song Xiaotong, Electrical Engineer | Core Technical Expert

- 20+ years in industrial electrical engineering.
- Led major projects across metallurgy, chemical, and oil & gas, saving 18% energy annually.
- Developed proprietary Full-Cycle Energy Efficiency Model, reducing failures 35% and boosting production 22%.
- Directed solid waste electrical upgrades with 92%+ energy recovery.
- Created Electrical-Mechanical-Control triad solutions, establishing industrial technology leadership.



Business License



National Industry Standard Participating Drafting Unit



National High-Tech Enterprise Certificate



Quality Management System Certificate

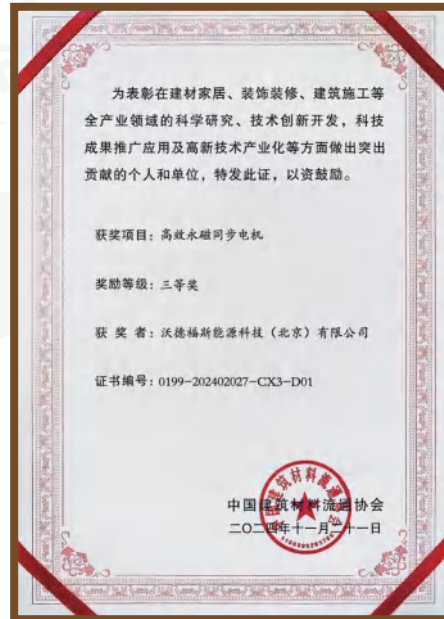

National Award Certificate for High-Efficiency Permanent Magnet Synchronous Motors

PATENT CERTIFICATE



Invention Patent: An Automatic Assembly Equipment for Magnetic Steel of Rotor in Interior Permanent Magnet Synchronous Motor



Utility Model Patent: A Surface-Mounted Magnetic Steel Rotor with Snap-Fit Connection and Installation Function



Utility Model Patent: An Assembly Tooling Assembly for Surface-Mounted Magnetic Steel of Permanent Magnet Motors



Software Name: Multi-Physics Field Coupling Simulation Platform for Permanent Magnet Motors



Software Name: Permanent Magnet Motor Electromagnetic Design and Optimization Analysis System



Software Name: Permanent Magnet Motor Testing and Energy Efficiency Estimation Software

SOFTWARE COPYRIGHT CERTIFICATE



Software Name: Permanent Magnet Motor Intelligent Control Cabinet Communication and Dispatch System



Software Name: Permanent Magnet Motor Fault Diagnosis and Life Prediction Analysis System



Software Name: Permanent Magnet Motor Remote Monitoring and Maintenance Cloud Platform



Software Name: MES (Manufacturing Execution Management System) for Permanent Magnet Motor Production Line



Software Name: Energy-saving start-stop optimization control software for permanent magnet motors



Software Name: Permanent magnet motor variable frequency speed control system



China Energy Label
Grade 1 (Highest Energy Efficiency)

Compliant with the national energy efficiency standard for permanent magnet synchronous motors.

此标识和铭牌同时使用。产品规格型号、效率、额定功率和额定转速见铭牌。

Issued by China National Institute of Standardization, Energy Labeling Management Center

Model: TYWF-180M-4/100
Energy efficiency label registration completed.

中国标准化研究院能效标识管理中心

兹证明

沃德福斯能源科技(北京)有限公司

TYWF-180M-4/100 型号

永磁同步电动机2013版产品

已完成能效标识备案, 特此证明。

备案号: 20230809-661100-60981691590650067

公告时间: 2023-08-09



2023年08月09日

注: 如单元备案, 且需要查看单元内型号列表, 请扫该型号标识二维码查询, 或者在能效标识网“备案公告”里通过备案号查询获取



Certificate of AAA Grade Credit Enterprise



Certificate of AAA Grade Good Faith Enterprise



Enterprise Credit Rating Certificate (AAA)



Certificate of AAA Grade Good Faith Demonstration Enterprise



Certificate of AAA Grade Integrity Enterprise on Quality & Service



Certificate of AAA Grade Credible Supplier Enterprise

PRODUCT ENERGY EFFICIENCY TEST REPORT

检测报告		第 5 页 第 1 页	
编号: 3N230744			
样品名称	高效永磁三相异步电动机	规格型号	TYWF-180M-4/100
		商标	WDFCS
轴(进)样序号	/	样品等级	合格品
轴(进)样地点	/	样品数量	1台
轴(进)样日期	/	样品基数	/
到样日期	2023-07-21	原编号或生产日期	2023年5月
检测完成日期	2023-07-24		
检测判定依据	GB 30253-2013, GB/T 22670-2008		
检测项目	效率		
检测结论	对沃德福斯能源科技(北京)有限公司生产的规格型号为TYWF-180M-4/100永磁同步电动机按照GB 30253的相关要求进行检测,所检项目合格,其能效等级为1级。 (以下空白)		
 2023年08月02日			

检测报告		第 5 页 第 1 页	
编号: 3N230745			
样品名称	高效永磁三相异步电动机	规格型号	TYWF-280S-6/75
		商标	WDFCS
轴(进)样序号	/	样品等级	合格品
轴(进)样地点	/	样品数量	1台
轴(进)样日期	/	样品基数	/
到样日期	2023-07-21	原编号或生产日期	2023年5月
检测完成日期	2023-07-25		
检测判定依据	GB 30253-2013, GB/T 22670-2008		
检测项目	效率		
检测结论	对沃德福斯能源科技(北京)有限公司生产的规格型号为TYWF-280S-6/75永磁同步电动机按照GB 30253的相关要求进行检测,所检项目合格,其能效等级为1级。 (以下空白)		
 2023年08月02日			

检测报告		第 5 页 第 1 页	
编号: 3N230746			
样品名称	高效永磁三相异步电动机	规格型号	TYWF-225M-8/66.6
		商标	WDFCS
轴(进)样序号	/	样品等级	合格品
轴(进)样地点	/	样品数量	1台
轴(进)样日期	/	样品基数	/
到样日期	2023-07-21	原编号或生产日期	2023年5月
检测完成日期	2023-07-26		
检测判定依据	GB 30253-2013, GB/T 22670-2008		
检测项目	效率		
检测结论	对沃德福斯能源科技(北京)有限公司生产的规格型号为TYWF-225M-8/66.6永磁同步电动机按照GB 30253的相关要求进行检测,所检项目合格,其能效等级为1级。 (以下空白)		
 2023年08月02日			

检测报告		第 5 页 第 1 页	
编号: 3N230747			
样品名称	高效永磁三相异步电动机	规格型号	TYWF-200L2-8/66.6
		商标	WDFCS
轴(进)样序号	/	样品等级	合格品
轴(进)样地点	/	样品数量	1台
轴(进)样日期	/	样品基数	/
到样日期	2023-07-21	原编号或生产日期	2023年5月
检测完成日期	2023-07-28		
检测判定依据	GB 30253-2013, GB/T 22670-2008		
检测项目	效率		
检测结论	对沃德福斯能源科技(北京)有限公司生产的规格型号为TYWF-200L2-8/66.6永磁同步电动机按照GB 30253的相关要求进行检测,所检项目合格,其能效等级为1级。 (以下空白)		
 2023年08月02日			

检测报告		第 5 页 第 1 页	
编号: 3N230213			
样品名称	高效永磁三相异步电动机	规格型号	TYWF-355M1-8/50
		商标	WDFCS
轴(进)样序号	/	样品等级	合格品
轴(进)样地点	/	样品数量	1台
轴(进)样日期	/	样品基数	/
到样日期	2023-07-21	原编号或生产日期	2023年5月
检测完成日期	2023-07-31		
检测判定依据	IEC 60034-30-2:2016, GB/T 22670-2018		
检测项目	效率		
检测结论	对沃德福斯能源科技(北京)有限公司生产的规格型号为TYWF-355M1-8/50永磁同步电动机按照IEC 60034-30-2的相关要求进行检测,所检项目合格,其能效等级为IE3。 (以下空白)		
 2023年08月02日			

WDFCS's full range of high-efficiency permanent magnet synchronous motors all comply with China's **Grade 1 Energy Efficiency standard (GB 30253-2024)** and fully meet the international **IE5 ultra-premium efficiency standard**.

Representative models include TYWF-180M-4/100, TYWF-280S-6/75, TYWF-225M-8/66.6, TYWF-200L2-8/66.6 and TYWF-355M1-8/50. With reliable, flawless operation and accurate metering, our motors deliver exceptional energy efficiency and substantial cost savings for customers.

ENERGY-SAVING PROJECT ACCEPTANCE REPORT

WDFCS 节能电机技改测试数据记录及报告

项目	测试地点	测试日期	测试人员
项目名称	山东XX有限公司	2023年07月02日	王XX
电机型号	Y2-280L-4	额定功率 (KW)	37
额定电压 (KV)	3.3	额定电流 (A)	7.5
额定转速 (r/min)	1470	二次绕组匝数	22.5
测试电压 (KV)	3.3	测试电流 (A)	6.5
测试转速 (r/min)	1470	测试功率 (KW)	28.5
测试效率 (%)	88.5	测试功率因数	0.85
测试温度 (°C)	45	测试环境温度	25
测试时间 (h)	1	测试地点	XX车间
测试人员	王XX	测试日期	2023年07月02日
测试地点	XX车间	测试日期	2023年07月02日
测试人员	王XX	测试日期	2023年07月02日

WDFCS 节能电机技改测试数据记录及报告

项目	测试地点	测试日期	测试人员
项目名称	山东XX有限公司	2023年07月02日	王XX
电机型号	Y2-280L-4	额定功率 (KW)	37
额定电压 (KV)	3.3	额定电流 (A)	7.5
额定转速 (r/min)	1470	二次绕组匝数	22.5
测试电压 (KV)	3.3	测试电流 (A)	6.5
测试转速 (r/min)	1470	测试功率 (KW)	28.5
测试效率 (%)	88.5	测试功率因数	0.85
测试温度 (°C)	45	测试环境温度	25
测试时间 (h)	1	测试地点	XX车间
测试人员	王XX	测试日期	2023年07月02日
测试地点	XX车间	测试日期	2023年07月02日
测试人员	王XX	测试日期	2023年07月02日

WDFCS 节能电机技改测试数据记录及报告

项目	测试地点	测试日期	测试人员
项目名称	山东XX有限公司	2023年07月02日	王XX
电机型号	Y2-280L-4	额定功率 (KW)	37
额定电压 (KV)	3.3	额定电流 (A)	7.5
额定转速 (r/min)	1470	二次绕组匝数	22.5
测试电压 (KV)	3.3	测试电流 (A)	6.5
测试转速 (r/min)	1470	测试功率 (KW)	28.5
测试效率 (%)	88.5	测试功率因数	0.85
测试温度 (°C)	45	测试环境温度	25
测试时间 (h)	1	测试地点	XX车间
测试人员	王XX	测试日期	2023年07月02日
测试地点	XX车间	测试日期	2023年07月02日
测试人员	王XX	测试日期	2023年07月02日

WDFCS 节能电机技改测试数据记录及报告

项目	测试地点	测试日期	测试人员
项目名称	山东XX有限公司	2023年07月02日	王XX
电机型号	Y2-280L-4	额定功率 (KW)	37
额定电压 (KV)	3.3	额定电流 (A)	7.5
额定转速 (r/min)	1470	二次绕组匝数	22.5
测试电压 (KV)	3.3	测试电流 (A)	6.5
测试转速 (r/min)	1470	测试功率 (KW)	28.5
测试效率 (%)	88.5	测试功率因数	0.85
测试温度 (°C)	45	测试环境温度	25
测试时间 (h)	1	测试地点	XX车间
测试人员	王XX	测试日期	2023年07月02日
测试地点	XX车间	测试日期	2023年07月02日
测试人员	王XX	测试日期	2023年07月02日

WDFCS 节能电机技改测试数据记录及报告

项目	测试地点	测试日期	测试人员
项目名称	山东XX有限公司	2023年07月02日	王XX
电机型号	Y2-280L-4	额定功率 (KW)	37
额定电压 (KV)	3.3	额定电流 (A)	7.5
额定转速 (r/min)	1470	二次绕组匝数	22.5
测试电压 (KV)	3.3	测试电流 (A)	6.5
测试转速 (r/min)	1470	测试功率 (KW)	28.5
测试效率 (%)	88.5	测试功率因数	0.85
测试温度 (°C)	45	测试环境温度	25
测试时间 (h)	1	测试地点	XX车间
测试人员	王XX	测试日期	2023年07月02日
测试地点	XX车间	测试日期	2023年07月02日
测试人员	王XX	测试日期	2023年07月02日

WDFCS 节能电机技改测试数据记录及报告

项目	测试地点	测试日期	测试人员
项目名称	山东XX有限公司	2023年07月02日	王XX
电机型号	Y2-280L-4	额定功率 (KW)	37
额定电压 (KV)	3.3	额定电流 (A)	7.5
额定转速 (r/min)	1470	二次绕组匝数	22.5
测试电压 (KV)	3.3	测试电流 (A)	6.5
测试转速 (r/min)	1470	测试功率 (KW)	28.5
测试效率 (%)	88.5	测试功率因数	0.85
测试温度 (°C)	45	测试环境温度	25
测试时间 (h)	1	测试地点	XX车间
测试人员	王XX	测试日期	2023年07月02日
测试地点	XX车间	测试日期	2023年07月02日
测试人员	王XX	测试日期	2023年07月02日

WDFCS has successfully delivered energy-saving retrofitting solutions for numerous asynchronous motors across various industrial scenarios including pumping stations and workshops. All units have been retrofitted with WDFCS TYWF series high-efficiency permanent magnet synchronous motors (PMSMs).

Strict on-site performance verifications before and after the retrofit confirm that all upgraded motors operate stably with substantially reduced temperature rise under rated conditions. The solutions deliver an average active power saving rate of **21.7% ~ 33.7%** and a maximum of **21.54 kWh** saved per hour per unit.

Tested by the Shanghai Electrical Apparatus Research Institute, the only national authoritative certification body, the motor efficiencies reach

97.39%, 97.43% and 97.45% respectively,

exceeding the Grade 1 national energy efficiency standard (the highest level)

Model	TYWF 280M-8/100				
Technical Parameters	380 V	100 Hz	90 kW	148.4 A	1500 rpm
	S1	F	IP54	cos ϕ =0.96	IE4

Load Test	0.5 P _n	0.75 P _n	1.0 P _n	1.25 P _n
Current (A)	174.2	254.8	346.6	461.0
Torque (N·m)	636.7	955.0	1273.3	1591.7
Speed (rpm)	1500.0	1500.0	1500.0	1500.0
Input Power (W)	102946	153808	205290	257742
Output Power (W)	100000	150000	200000	250000
Efficiency (%)	97.07	97.57	97.43	96.98
Power Factor	0.950	0.938	0.931	0.902

Model	TYWF 315L2-6/75						
Technical Parameters	380 V	75 Hz	200 kW	354 A	1500 rpm	Y	
	S1	F	IP55	$\eta=97.2\%$	$\cos \phi=0.96$	IE4	800 kg

Load Test	0.5 Pn	0.75 Pn	1.0 Pn	1.25 Pn
Current (A)	75.18	111.7	151.3	195.6
Torque (N·m)	286.5	429.8	573.0	716.2
Speed (rpm)	1500.0	1500.0	1500.0	1500.0
Input Power (W)	46381	69270	92357	115850
Output Power (W)	45000	67500	90000	112500
Efficiency (%)	96.96	97.49	97.45	97.10
Power Factor	0.985	0.979	0.969	0.948

Model	TYWF 280-6/75						
Technical Parameters	380 V	75 Hz	90 kW	154 A	1500 rpm	Y	
	S1	F	IP55	$\eta=96\%$	$\cos \phi=0.95$	450 kg	

Load Test	
Current (A)	156.8
Torque (N·m)	573.0
Speed (rpm)	1500.0
Input Power (W)	93506
Output Power (W)	9000
Efficiency (%)	97.39
Power Factor	0.987

TYWF Series Low-Voltage Permanent Magnet Synchronous Motors

- Power Range: **7.5 kW ~ 400 kW (380 V)**
- Advanced Control: Soft start and soft stop via variable frequency drive (VFD), ensuring low starting current.



01

Replacement of Asynchronous Motors

Designed with the same installation dimensions and protection rating as the Y, Y2, and YE series, providing seamless interchangeability.

02

Key Features and Advantages

Featuring high efficiency and power factor, superior starting torque, low noise and vibration, safe and reliable operation, and optimal energy savings.

03

High Efficiency and Energy Saving

These motors achieve efficiency levels above Grade 1 (IE5), surpassing the energy efficiency standards defined in GB 30253-2024 for permanent magnet synchronous motors and GB 18613-2020 for electric motors.

04

Extensive Applications

These motors are extensively used in a broad range of industrial equipment, serving sectors including petroleum, chemical processing, wastewater treatment, metallurgy, cement, rubber, paper, and pharmaceuticals.

TYWFG Series 6kV/10kV High-Voltage Permanent Magnet Synchronous Motors

- ⦿ Power Range: **280 kW ~ 5000 kW**
- ⦿ Advanced Control: Variable frequency drive (VFD) for smooth operation and precise regulation.



01

Structural Design

Compact frame with axial or centrifugal surface forced-air cooling, replacing conventional air-to-air and air-to-water cooling systems for a simpler, highly maintainable design.

02

Key Features and Advantages

Featuring high efficiency and power factor, superior starting torque, low noise and vibration, safe and reliable operation, and optimal energy savings.

03

High Efficiency and Energy Saving

These motors deliver remarkable energy efficiency, reducing electricity consumption by **2% ~ 8%** under similar operating conditions.

04

Replacement of Asynchronous Motors

Engineered according to the frame sizes of conventional high-voltage induction motors, this series can seamlessly replace Y, YKK, YKS, YRKK, and other high-voltage induction motor series.

TYWFZ Direct-Drive Series Permanent Magnet Synchronous Motors

- ⦿ Direct-Drive Design: High-efficiency power transmission without reduction gears.
- ⦿ Customizable Configuration: Tailored design and layouts for diverse equipment and environments.
- ⦿ Wide Voltage Range: Available in **380 V / 660 V / 1140 V / 6 kV / 10 kV**.



01

Power Supply Mode

Driven by a variable-frequency drive (VFD), the motor precisely matches load speed and torque requirements, eliminating gear reducers and buffer mechanisms from the transmission system and simplifying the overall drive configuration.

02

Key Features and Advantages

Features high transmission efficiency, superior starting torque, energy-saving performance, ultra-low noise, minimal vibration, low temperature rise, reliable and safe operation, with reduced installation and maintenance costs.

03

Direct-Drive Motor

Eliminates the limitations of traditional induction motor and gearbox transmission systems by delivering direct-drive power to the load.

04

Extensive Applications

Extensively used across coal mining, mineral processing, cement, metallurgy, power generation, chemical, and building materials industries, powering a wide range of machinery including ball mills, belt conveyors, mixers, hoists, crushers, filter machines, and plastic extruders.

TYWFJ Series Permanent Magnet Synchronous Motors with Permanently Magnetized Asynchronous Rotor

- ⦿ Power Range: **7.5 kW ~ 400 kW (380 V)**, suitable for a wide spectrum of industrial applications.
- ⦿ Rotor Magnetization Upgrade: Converts legacy asynchronous motor rotors into permanent magnet synchronous rotors using advanced magnetization technology, without altering the original stator or frame.

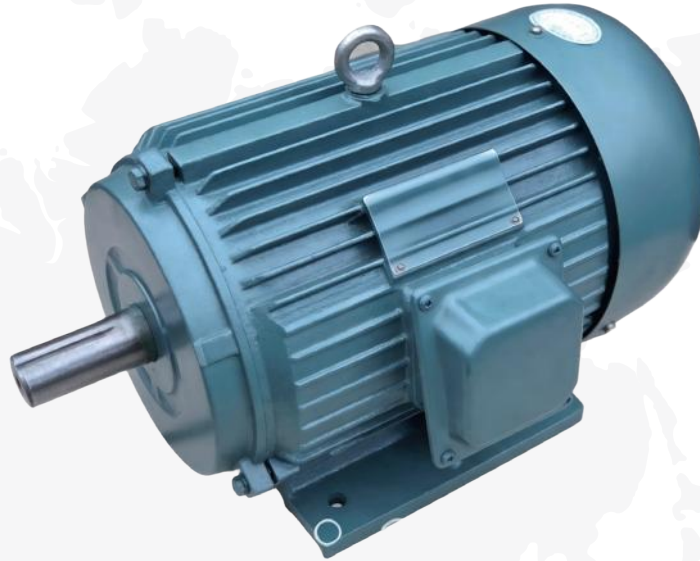

01

Energy Efficiency Breakthrough

Exceeding Level 2 energy efficiency standards of GB30253 2024 for permanent magnet synchronous motors, the design retains the original motor structure and mounting dimen-

02

Key Features and Advantages

Core technology of this series lies in the permanent magnetization of cast-aluminum rotors in low-voltage three-phase asynchronous motors.

03

High Efficiency & Energy Saving

Compared to the original three-phase asynchronous motor, the upgrade delivers a **10% ~ 30%** improvement in power factor, **2% ~ 8%** higher rated efficiency, and a permanent magnet rotor that operates free of eddy current losses.

04

PMSM Energy-Saving Retrofit

Maximizes the use of legacy JS, JR, Y, Y2, and YE2 series three-phase asynchronous motor cast-aluminum rotors, ensuring high material efficiency and cost-effective, reliable performance.

Customized Product Solutions

- Tailored for Low- and High-Speed Direct-Drive Systems

Systems are designed according to on-site operating conditions, including low-speed high-torque and high-speed direct-drive applications, maximizing overall system efficiency.

- Smart Remote Control & Monitoring

Utilizes wireless communication technology for fully customized remote control, monitoring, and drive of the entire system, with dynamic management based on required production levels.

- Flexible Speed and Torque Ranges

- Low-Speed Direct-Drive Systems: Speed range 5 ~ 200 rpm with maximum torque up to 300,000 N·m.
- High-Speed Systems: Multi-stage operation across 3,000 ~ 12,000 rpm, and extended levels of 15,000, 18,000, and 22,000 rpm, depending on power ratings.

- Simplified Transmission & Easy Maintenance

High-efficiency, energy-saving design significantly reduces overall transmission complexity and improves system operability and maintenance convenience.

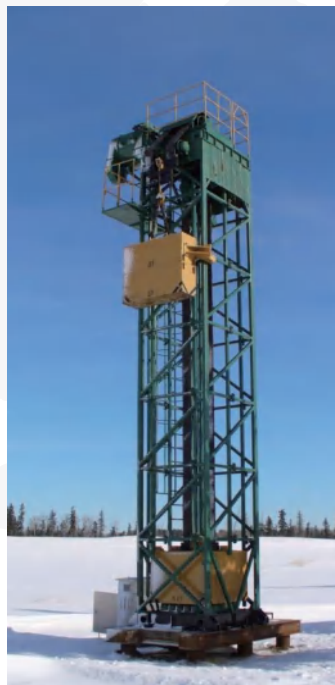

*Submersible Centrifugal Pump
High-Speed Drive System*



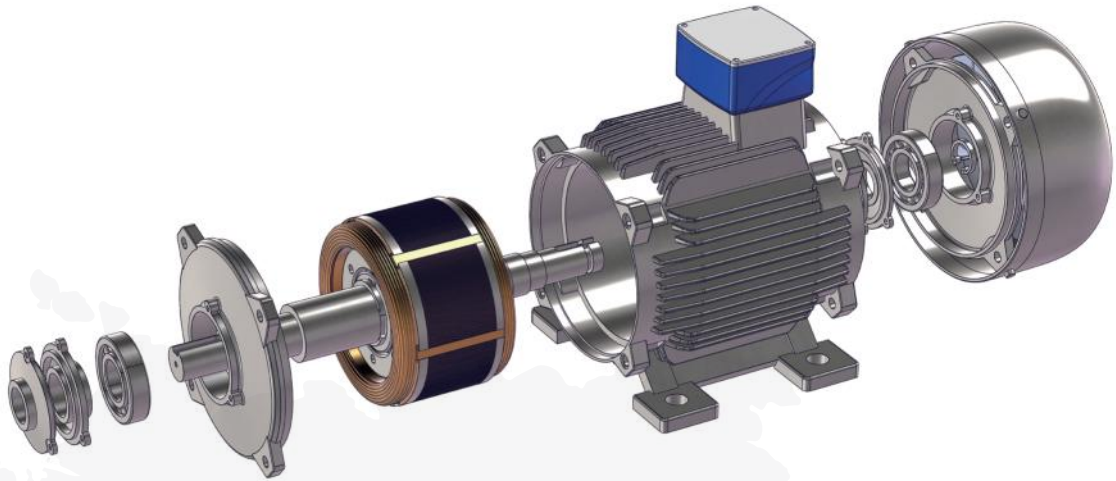

WDFCS Permanent Magnet Motors and Control Systems



01

The motor is equipped with a variable frequency drive (VFD) control system, ensuring smooth start-up, enhanced protection, and simplified control. It enables soft start and soft stop functions (with starting current limited to 1.2 times the rated current), effectively avoiding high inrush current impacts on equipment and the power grid, while extending the service life of cables.

02

Remote Control: The system supports full remote operation, including remote monitoring, data acquisition, and PLC-based control capabilities.

03

The motor control cabinet is equipped with filters and reactors, with shielded control and data acquisition lines to improve data accuracy.

04

Control and Mechatronics: Implements vector control of permanent magnet synchronous motors, accurately reading static and dynamic motor parameters. Based on operating conditions, it automatically adjusts motor flux, back EMF, and other parameters to ensure the motor always operates at optimal efficiency and is fully adapted to current working conditions.

Motor Retrofit at a Steel Company in Xuanhua, Hebei



After Retrofit of the 2,500 kW Main Shaft Fan

Main Induced Draft (ID) Fan
Average Current Decreased
15%



After Retrofit of the 1,250 kW Coal Pulverizers

Pulverizers
Average Current Decreased
21%



After Retrofit of the 900 kW Induced Draft Fan

Induced Draft (ID) Fan
Average Current Decreased
44%

Current Comparison Before and After Retrofit

	No. 1 Furnace			No. 2 Furnace			No. 3 Furnace3		
	Main ID Fan	Pulverizers	ID Fan	Main ID Fan	Pulverizers	ID Fan	Main ID Fan	Pulverizers	ID Fan
Power (kW)	2500	1250	900	2500	1250	560	1000	900	315
Current Before Retrofit (A)	108-99	50-60	20-24	113-102	45-55	18-20	75-85	50-55	28-29
Current After Retrofit (A)	92-74	40-52	9-12	97-80	32-45	9-10	63-51	43-51	20-25



**XUANHUA STEEL PLANT, HEBEI
IRONMAKING PLANT, SINTERING
SECTION (12 UNITS)**

Total Installed Power of
Original Asynchronous
Motors:
2134 kW



**XUANHUA STEEL PLANT, HEBEI
NO. 1 ROLLING MILL (14 UNITS)**

Total Installed Power (Original
Asynchronous Motors):
1605 kW

Energy Savings:
272 kWh per hour

Annual Energy Savings
(Based on 8,000 Operating Hours):
2.18 million kWh



XUANHUA STEEL PLANT, HEBEI

Retrofitted Motor Power:
75 - 250 kW

Energy Savings:
21%



**METALLURGICAL
INDUSTRY**



TANGSHAN STEEL PLANT, HEBEI

Reheating Furnace Circulating Water Pump Retrofit

Motor Power:
160 kW



CHENGDE STEEL PLANT, HEBEI
WATER SUPPLY PUMP SYSTEM

Total Installed Power (Original
Asynchronous Motors):
110 kW

Energy Savings:
30.02 kWh per hour

Annual Energy Savings
(Based on 8,000 Operating Hours):
240,000 kWh



TANGSHAN STEEL PLANT, HEBEI

Total Installed Power (Original
Asynchronous Motors):
200 kW

Energy Savings:
52.43 kWh per hour

Annual Energy Savings
(Based on 8,000 Operating Hours):
420,000 kWh



A Nonferrous Metals Group in Shaanxi



Economic Benefits Analysis of Retrofit

No.	Equipment Name	Function	Original Motor Model	Replaced Motor Model	Power (kW)	Annual Operating Hours	Power Consumption Before Retrofit	Water Supply Before Retrofit (t/h)	Specific Consumption (t/kWh)	Power Consumption After	Water Supply After Retrofit (t/h)	Specific Consumption (t/kWh)	Energy Savings (%)
1	No. 4 Screw Air Compressor (Zone II)	Air Compressor	Y200L-2	TY200L-3000	37	8526	26	150	0.17	23	150	0.15	12%
2	No. 3 Centrifugal Pump (Process Water)	Centrifugal Pump	YJTG315M1-4	TY315M-1500	220	7643	154	476.8	0.32	87	476.8	0.18	44%
3	No. 6 Centrifugal Pump (Process Water)	Centrifugal Pump	Y200L-2	TY200L-3000	37	3223	37	128	0.29	28	130	0.22	24%
4	No. 7 Centrifugal Pump (Process Water)	Centrifugal Pump	YJTG280S-2	TY280S-3000	75	7667.5	64	211	0.3	33	211	0.16	47%
5	No. 2 Centrifugal Pump (Circulating Water)	Centrifugal Pump	J094-2	TY280M-3000	90	5322	81	157	0.52	45	157	0.29	44%
6	No. 4 Centrifugal Pump (Circulating Water)	Centrifugal Pump	Y315S-2	TY315S-3000	90	8332	112	251	0.45	74	251	0.29	36%
7	No. 1 Centrifugal Pump (Recirculation)	Centrifugal Pump	Y200L-4	TY200L-1500	30	4323	18.1	100	0.18	2.87	100	0.03	83%
8	No. 6 Centrifugal Pump (Recirculation)	Centrifugal Pump	Y280S-4	TY280S-1500	75	4737	31	76	0.41	26	90	0.29	29%
9	No. 9 Centrifugal Pump (Recirculation)	Centrifugal Pump	Y250M-4	TY250M-1500	55	6266	55.6	300	0.19	20.4	300	0.06	68%
10	No. 11 Centrifugal Pump (Recirculation)	Centrifugal Pump	JS2-355M1-4	TY315M-1500	160	8656	126.1	645	0.2	57.3	645	0.09	55%
11	No. 13 Centrifugal Pump (Recirculation)	Centrifugal Pump	Y180M-4	TY180M-1500	18.5	4602	18.1	100	0.18	7.4	100	0.07	60%
12	No. 1 Centrifugal Pump (Newly Installed)	Centrifugal Pump	Y250M-2	TY250M-3000	55	7867	36.7	94	0.39	21.7	94	0.23	41%
13	No. 6 Industrial Water Pump (Industrial Park)	Centrifugal Pump	Y2-225M-2	TY225M-3000	45	7170	42.9	120	0.35	36.8	155	0.24	31%



Chifeng Nonferrous Metals Company, Inner Mongolia

Case Description

The three-phase asynchronous motor drive systems of 18 coal pulverizers, with a total installed capacity of **1,250 kW**, were upgraded to high-efficiency permanent magnet synchronous motor (PMSM) drive systems.

Performance Results

- Total Motor Power (Before Retrofit): **1,250 kW**
- Annual Energy Savings: **2.35 million kWh**
- Annual Standard Coal Savings: **764 tons**
- Annual CO2 Emission Reduction: **2,343 tons**

Project Impact

With the remarkable achievements in energy conservation and carbon reduction, the company was awarded the title of **Green Factory** by the Department of Industry and Information Technology of Inner Mongolia Autonomous Region in 2022.



Shaanxi Nonferrous Metals Group

Water Pump Application – Shaanxi Nonferrous Metals Group

Motor Rating: **200 kW / 380 V / 1500 rpm**

31%

Annual Energy Savings

Kiln Main Drive Retrofit: From DC Motor to AC Permanent Magnet Synchronous Motor (PMSM)

Chengde Cement Plant, Hebei

The original drive system consisted of a DC motor combined with a thyristor-controlled DC drive. DC motors were applied due to their high starting torque and good responsiveness to load fluctuations. However, due to inherent limitations of DC motors and the specific operating conditions of the kiln main drive, several issues were observed, including low efficiency, high operating current, low protection rating, and heavy maintenance requirements.

By integrating permanent magnet drive technology with AC electronic speed control technology, not only can the above-mentioned drawbacks under such operating conditions be effectively eliminated, but energy savings and consumption reduction can also be maximized.

Compared with the original DC drive system, maintenance requirements are significantly reduced, enabling the low-carbon operation currently advocated.

According to actual operational testing, the system after retrofit can achieve:

17%
Energy Savings



Cement Belt Conveyor Direct-Drive Motor Retrofit

Replacement of Conventional Induction Motor-Reducer Systems with Permanent Magnet Direct-Drive Motors



Shandong Cement Plant



Retrofit Solution

The original 55 kW / 1480 rpm induction motor was replaced with a 55 kW / 48 rpm permanent magnet direct-drive motor, delivering a rated torque of 11,000 N·m.

Key Advantages

- Eliminates the gearbox, enabling direct drive of the conveyor system.
- Simplifies the drivetrain structure and improves system reliability.
- Significantly reduces maintenance costs, especially those associated with gear reducers.
- Removes the need for auxiliary oil pump systems, lowering operational complexity and energy consumption.

35%

Energy Savings through
Direct-Drive Technology

Shandong Cement Plant (Excluding Dust Collection Section)

Excluding Dust Collection Section

No.	Motor Installation Location	Motor Model	Power (kW)	Quantity	Operating Frequency (Hz)	Annual Energy Savings (10 kWh)	Annual Cost Savings (10 CNY)
1	Limestone Baghouse Dust Collector Blower	TY-280-4	90	1	30 - 40	10	7
2	Primary Coal Roots Blower	TY-280-4	90	1	45	11.8	8.3
3	Secondary Coal Roots Blower	TY-315M-4	132	1	46	17.4	12.2
4	Primary Air Blower	TY-315M-4	132	1	47	17.4	12.2
5	Mill Head Baghouse Dust Collector Blower	TY-315S-4	110	1	48	14.5	10
6	Baghouse Dust Collector Blower Motor	TY-250-4-B3	55	2	45	14.5	10
7	Cooling Tower Fan	TY-280S-4	75	2	20 - 42	9.2	6.4
Total			684	9		94.8	66.1



Ball Mill Application -
Jiangxi Mining Company

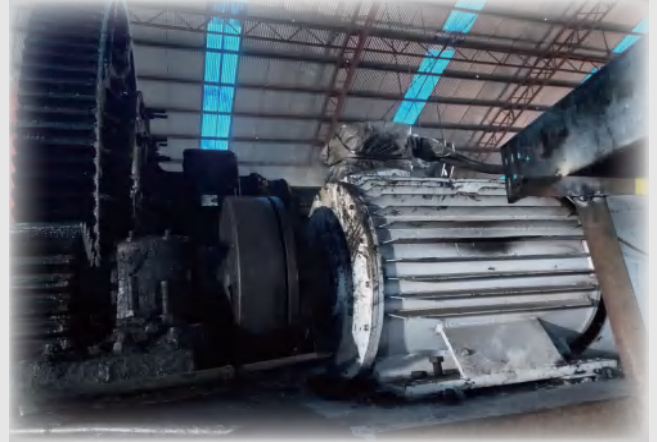

Active Energy Savings
25.7%



Liaoning Energy Company

Comprehensive Energy Savings
19.1%

Shandong Chemical Company

Brine Pump Motor Upgrade

Pre- and Post-Retrofit Comparison

- ⦿ Current: Reduced from **52.6 A to 43.2 A** (↓17.9%)
- ⦿ Hourly Energy Consumption: Reduced from **662 kWh to 569 kWh** (Energy Savings: 13.9%)

Annual Performance

(Based on 7,200 hours of continuous operation over 10 months)

- ⦿ Annual Energy Savings: **669,600 kWh**
- ⦿ Annual Cost Savings: **468,700 CNY**



Pre-Retrofit



Post-Retrofit

Hubei Bioengineering Company

Project Overview

A total of 22 three-phase induction motors, with a combined installed capacity of 1,925 kW, were upgraded to permanent magnet synchronous motors (PMSMs).

Energy & Environmental Benefits

- ⦿ Annual Energy Savings: **2.38 million kWh**
- ⦿ Standard Coal Savings:
2.38 million kWh × 0.303 kg/kWh = **721 tons/year**
- ⦿ CO₂ Emission Reduction:
2.38 million kWh × 0.997 kg/kWh = **2,372.9 tons/year**
- ⦿ SO₂ Emission Reduction: **71.4 tons/year**



Economic Benefits of Energy-Efficient Motor Retrofit (22 Units | Total Installed Capacity: 1,925 kW)

No.	Equipment Name	Function	Original Model	Replacement Model	Power	Qty	Hours	Before	After	Saving	Annual Saving	Rate
1	No. 2 Intermediate Pump	Pump	Y250M-4	TYC-250M-8-100	55	2	7200	54	43.9	10.1	14.54	18.7%
2	No. 1-4 Circulating Cooling Water Pumps	Pump	Y2-280M-4	TYC-280M-8-100	90	4	7200	89	70.9	18.1	52	20.3%
3	No. 1 Compression Circulating Water	Pump	Y355M2-4	TYC-355M1-8-10	250	1	7200	220	165.9	54.1	38.96	24.6%
4	No. 3 Purification Circulating Water	Pump	Y2-280S-4	TYC-280S-8-100	75	1	7200	75	62.5	12.5	9	16.7%
5	Purification Exhaust Fan	Fan	Y315S-6	TYC-315S-6-50	75	1	7200	68	54.8	13.2	9.5	19.4%
6	No. 3 Compression Circulating Water	Pump	YE2-355L2-6	TYC-355L-6-50	250	1	7200	222	166.1	55.9	40.25	25.2%
7	No. 4 Purification Circulating Water	Pump	Y280S-4	TYC-280S-4-50	75	1	7200	69	56.3	12.7	9.1	18.4%
8	No. 2 Compression Circulating Fan	Fan	Y225-4	TYC-225M-4-50	45	1	7200	36	30.9	5.1	3.67	14.2%
9	Desulfurization Circulating Pumps	Pump	Y225-4	TYC-225M-4-50	45	3	7200	38	31.8	6.2	13.38	16.2%
10	Desulfurization Circulating Pump	Pump	Y280M-4	TYC-280M-4-50	90	1	7200	72	56.4	15.6	11.23	21.6%
11	No. 2 Synthesis Circulating Hot Water	Pump	Y2-355L2-6	TYC-355M-6-50	185	1	7200	173	142.9	30.1	21.67	17.4%
12	No. 1-5 Slurry Pressurizing Pumps	Pump	Y250M-4	TYC-250M-4-50	55	5	7200	44	37.2	6.8	24.5	15.4%

Ningxia New Materials Company

Circulating Cooling Water Pump System Upgrade

Replacing YE2-280S-4 (75 kW) Induction Motor with TYWF280S-6/75 (75 kW) PMSM

Energy Performance (Measured Results)

Based on on-site testing:

- Average Energy Savings:
14.57 kWh
- Annual Cost Savings:
52,000 CNY
- Energy Saving Rate:
17.1%



WDFCS 节能电机测试数据记录及报告

项目名称	新材料有限公司循环水泵		项目地点	宁夏中卫市沙坡头区				
测试单位	新材料有限公司		实施单位	沃德福斯能源科技(北京)有限公司				
测试前异步电机基本情况及运行数据采集	电机基本情况及数据		电机位号	型号	额定功率 (KW)	额定转速	额定效率 (%)	额定电流 (A)
	2#, 3#循环水泵		YE3-280S-4	75	1490	95		
	电机运行数据		运行电流 (A)	运行电压 (v)	运行温升 (°C)	初次记录日期	二次记录日期	
			380			2023.10.31	2023.11.19	
测试后节能电机基本情况及运行数据采集	电机基本情况及数据		电机位号	型号	额定功率 (KW)	额定转速	额定效率 (%)	额定电流 (A)
	2#, 3#循环水泵		TYWF-280S-6/75	75	1500	96.8		
	电机运行数据		运行电流 (A)	运行电压 (v)	运行温升 (°C)	初次记录日期	二次记录日期	
			380			2024.1.6	2024.2.18	
测试后电机节能情况	2#, 3#综合每小时有功节电 (kw·h)		2#, 3#综合有功节电率 (%)					
	14.57		11.01					
计量系统说明	设备运行情况							
设备运行情况	2#, 3#两台水泵同时运行测量。							
测试单位:	新材料有限公司		实施单位:	沃德福斯能源科技(北京)有限公司				
负责人:	[Signature]		负责人:	[Signature]				
数据记录人员:	[Signature]		数据记录人员:	[Signature]				
	2024年2月26日			2024年2月19日				

WDFCS's on-site test report for energy-saving motors at a Ningxia New Materials Company.

Comparing conventional asynchronous motors with permanent magnet synchronous motors, the verified active power saving rate reaches **14.52%** (9.84 kWh saved per hour).

WDFCS's on-site test report for energy-saving motors at a Ningxia New Materials Company.

Comparing conventional asynchronous motors with permanent magnet synchronous motors, the verified comprehensive active power saving rate reaches **11.01%** (14.57 kWh saved per hour).

WDFCS 节能电机测试数据记录及报告

项目名称	新材料有限公司循环水泵		项目地点	宁夏中卫市沙坡头区				
测试单位	新材料有限公司		实施单位	沃德福斯能源科技(北京)有限公司				
测试前异步电机基本情况及运行数据采集	电机基本情况及数据		电机位号	型号	额定功率 (KW)	额定转速	额定效率 (%)	额定电流 (A)
	3#循环水泵		YE3-280S-4	75	1490	95	136	
	电机运行数据		运行电流 (A)	运行电压 (v)	运行温升 (°C)	初次记录日期	二次记录日期	
			120	380		2023.10.31	2023.11.19	
测试后节能电机基本情况及运行数据采集	电机基本情况及数据		电机位号	型号	额定功率 (KW)	额定转速	额定效率 (%)	额定电流 (A)
	3#循环水泵		TYWF-280S-6/75	75	1500	96.8	129	
	电机运行数据		运行电流 (A)	运行电压 (v)	运行温升 (°C)	初次记录日期	二次记录日期	
			95	380		2024.1.6	2024.2.18	
测试后电机节能情况	每小时有功节电 (kw·h)		有功节电率 (%)					
	9.84		14.52					
计量系统说明	设备运行情况							
设备运行情况	2#, 3#两台水泵同时运行测量。							
测试单位:	新材料有限公司		实施单位:	沃德福斯能源科技(北京)有限公司				
负责人:	[Signature]		负责人:	[Signature]				
数据记录人员:	[Signature]		数据记录人员:	[Signature]				
	2024年2月26日			2024年2月19日				

Daqing Oilfield – Oil Transfer Station

Energy Consumption Comparison (3-Month Analysis)

The station is equipped with four water-flooding oil transfer pumps, including:

- Two units driven by our 160 kW integrated permanent magnet motor (PMSM) drive systems
- The remaining units driven by conventional induction motors

Energy Consumption Data (Post-Retrofit Analysis)

Collected and analyzed operating data shows the following results:

- Period 1:
PMSM: **37,027 kWh** vs. Induction Motor: 104,140 kWh
- Period 2:
PMSM: **68,355 kWh** vs. Induction Motor: 98,276 kWh
- Period 3:
PMSM: **50,064 kWh** vs. Induction Motor: 82,904 kWh

Energy Consumption Comparison (3-Month Analysis)

Based on a three-month analysis of power consumption, the energy usage of permanent magnet motors (PMSMs) relative to induction motors is as follows:

- Month 1: 35.56%
- Month 2: 69.57%
- Month 3: 60.39%
- Overall Energy Saving Rate: **54.48%**

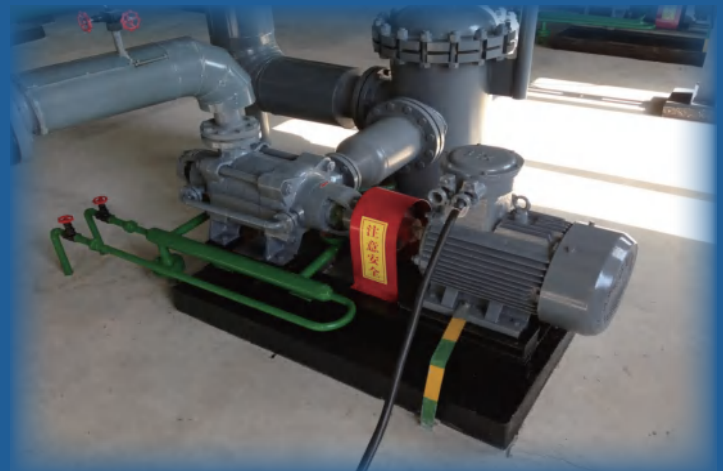

System Configuration

The oil transfer station is equipped with three oil pumps, including:

- ⦿ Two units driven by our 75 kW integrated permanent magnet motor drive systems
- ⦿ One unit driven by a 75 kW line-frequency induction motor



Daqing Oilfield – Oil Transfer Station

Energy Savings Analysis (4-Month Evaluation)

Based on a four-month comparison between variable-frequency PMSM systems and conventional line-frequency induction motors, the energy savings performance is as follows:

- ⦿ Month 1: 39.97%
- ⦿ Month 2: 63.45%
- ⦿ Month 3: 71.58%
- ⦿ Month 4: 61.89%

Average Energy Savings: **59.2%**

Key Conclusion

Overall, the permanent magnet variable-frequency motor system achieves approximately **40%** energy savings compared to conventional induction motor systems.

A Global Personal
Care Products
Company

Retrofit Solution

The TYWF315M-8/100 (132 kW) permanent magnet synchronous motor (PMSM) was installed to replace the original YE2-315M-4 induction motor used in the paper machine vacuum pump system.

Testing results indicate an average energy saving of **11.23 kWh**,

corresponding to an energy saving rate of **16.5%**.



Retrofit Solution

Pump Drive System Upgrade:

Replacing Y2-315L-4 (160 kW) Induction
Motor with TYWF315L-8-100 (160 kW)
PMSM

Liaoning Paper
Company



Testing results indicate an
average energy saving of
27.58 kWh,
corresponding to an energy
saving rate of **22%**.



R&D, Manufacturing, Sales & Service

WORLD FOCUS ENERGY TECHNOLOGY (BEIJING) CO., LTD.



Tel: +86 130 0225 9196

Email: ji.niu@wdfcs-cn.com

Website: <https://www.wdfcs-cn.com/>

Address: Room 1208-1210, Building 3, No. 9 Guang'an Road, Fengtai District, Beijing, P.R. China